

Heavy Duty Universal Multi-Head Towbars

Models: 01-1290-0100, 01-1293-0000

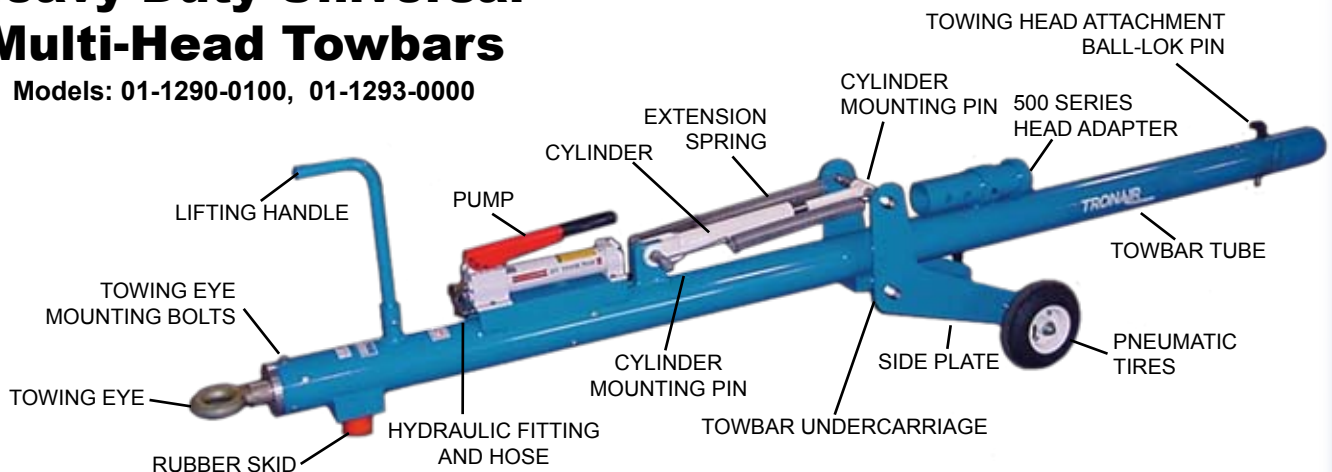

Tronair recommends towbar inspections at least once a week.

- Check towing eye for bending, excessive wear and deformity. If any are located, remove towbar from service and contact Tronair for repair.
- Check towing eye mounting bolts. Ensure the fasteners are tight and not missing. Tighten to 25 ft-lbs or replace as required.
- Ensure the towing eye does not move or turn by hand; if the towing eye can turn this may indicate that the centering pin within the shock assembly may be broken and repairs are needed. Contact Tronair for repairs.
- Check the shock assembly for preload on the spring by pulling on the towing eye. If the shock can be moved by hand this may indicate the spring is worn out, contact Tronair for repairs.
- Check the rubber skid at the towing eye end. Ensure that all fasteners are tight and not missing. Tighten or replace as required. If the bumper is split or excessively worn, contact Tronair or your Tronair distributor for replacement.
- Inspect the lifting handle for damage. Contact Tronair or your Tronair distributor for repair or replacement if required.
- Inspect the towbar tube for cracks, gouges greater than 1/16", and bends or deformities. If any are located, remove towbar from service and contact Tronair for repair.
- Inspect the pump for hydraulic leaks. Replace seals if any leaks exist. Contact Tronair or your Tronair distributor for replacement.
- Inspect hydraulic fittings and hose for leaks. If any hydraulic leaks exist, contact Tronair or your Tronair distributor for replacement.
- Inspect cylinder for hydraulic leaks. If any hydraulic leaks exist, contact Tronair or your Tronair distributor for replacement seals.
- Check extension springs. Extend cylinder to full stroke and open relief valve on pump. The extension springs should retract the cylinder completely. If not, contact Tronair or your Tronair distributor for replacement.
- Inspect cylinder mounting pins for bending or damage. Ensure the springs are engaged on them. If pins are bent or damaged, contact Tronair or your Tronair distributor for replacement.
- Check the towbar undercarriage for unusual wear or damage. Inflate the pneumatic tires to the proper pressure; repair any air leaks or replace if needed. Ensure the wheels can rotate freely, and wheel rims and tire axle are not bent. Ensure mounting fasteners are tight and not missing. Tighten or replace as required. Grease tire axle every 90 days.
- Inspect towbar undercarriage side plates for bending or damage. If any exist, contact Tronair or your Tronair distributor for replacement.
- Inspect head adapter for Tronair 500 series towing heads. Ensure it is not damaged or missing. Contact Tronair or your Tronair distributor for replacement if required.
- Inspect towing head attachment ball-lok pin for bending or unusual wear. Verify the factory supplied pin is used. Contact Tronair for replacement if required. Use only Tronair specified ball-lok pins.
- Ensure the towing head attachment ball-lok pin is connected to the towbar via its lanyard. Replace lanyard if missing.
- Inspect all steel components for signs of rust. Touch up with paint as required.

INS-1792

www.tronair.com

Tronair • Email: sales@tronair.com • Phone: 419-866-6301 or 800-426-6301 • Fax: 419-867-0634

Asia Sales Offices: China - Email: tronairchina@tronair.com • Phone: 86-592-5560735 • Fax: 86-592-5563132

Asia/Australia - Email: tronairasia@tronair.com • Phone: 66-2665-6511 • Fax: 66-2204-1858

Europe, Middle East & Africa Sales Office • Email: saleseurope@tronair.com • Phone: 44-0-113-245-3300 • Fax: 44-0-113-322-0436