

## Engine Stands

Easy access to the entire jet engine

## Mobile Engine Work Stands



### Standard Features:

Models: 08-2014-0000, 08-2018-0000, 08-2029-0000, 08-2030-0000, 08-2034-0000

- Heavy duty welded steel construction
- Easy maneuvering with 2 swivel and 2 rigid heavy duty casters
- Rigid casters equipped with floor locks
- Handy oil recovery pan to avoid damage to hanger floors
- Easily converted to accept left and right hand engines
- Multiple engine adaptability (engine adaptor kits sold separately)
- Removable towbar with storage hooks
- Adaptors change in minutes
- Finish: Durable Powder Coat Tronair Blue

### Standard Features:

Model: 08-2037-0000

- Heavy duty welded steel construction
- One ton lift capacity
- Electric motor operated
- Adjustable from 30 to 73 inches at engine centerline
- Easy maneuvering with 4 lockable, swivel heavy duty casters
- Easily converted to accept left and right hand engines
- Multiple engine adaptability (engine adaptor kits sold separately)
- Removable towbar with storage hooks
- Anti-slip mats on all work/walking surfaces
- Finish: Durable Powder Coat Tronair Blue

### Adaptor Kits:

08-2030-0000 - 08-2034-0010

- K-2685 - Pratt & Whitney PW530A
- K-2769 - Pratt & Whitney PW545A
- K-2770 - Garrett TFE731-1 to 5
- K-2776 - Pratt & Whitney JT15D-1 to 5
- K-2808 - Garrett TFE731-20
- K-3068 - Pratt & Whitney PW535
- K-4093 - Pratt & Whitney PWC127

08-2034-0010 only

- K-3152 - Pratt & Whitney PW306A
- K-3618 - Pratt & Whitney PW308A
- K-3842 - Pratt & Whitney PW306C
- K-4192 - Hawker 900XP 731-50R Engine

Model: 08-2037-0000

- K-4662 - Garrett TFE731-20
- K-4663 - Pratt & Whitney PW305

## Specifications:

Model Number	Manufacturer/ Engine	Length in (cm)	Width in (cm)	Height in (cm)	Weight lb (kg)
08-2014-0000	Pratt & Whitney - PW100	86 (218)	38 (97)	45 (114)	540 (245)
08-2018-0000	Pratt & Whitney - PW305	105 (267)	49 (125)	63 (160)	550 (250)
08-2029-0000	Rolls Royce (Allison) - AE-3007-C	120 (305)	61 (155)	83 (211)	960 (435)
08-2030-0000	Various - See Adaptor Kits	73 (185)	55 (140)	60 (152)	485 (220)
08-2034-0010	Various - See Adaptor Kits	133 (338)	70 (178)	60 (152)	650 (295)
08-2037-0000	Pratt & Whitney - PW307B	102 (259)	105 (267)	85 (216)	4,000 (1,814)



08-2034-0010



08-2037-0000

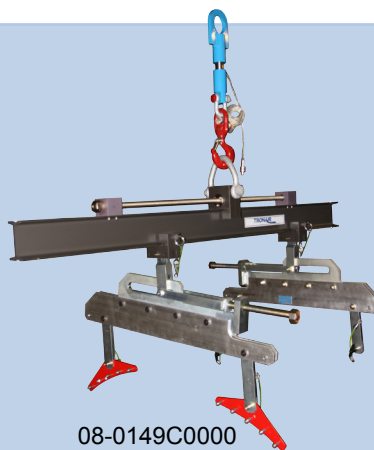

08-0149C0000

The 08-0149C0000 Engine Sling is designed to lift the Lear 85 engine. The sling may be used in conjunction with the 08-2037-0000 Mobile Engine Lift Stand in the manufacturing or engine servicing process. The sling is equipped with a load cell with hand held digital display to indicate when the engine is fully supported by the aircraft. The sling is fully adjustable.

# Multi-Purpose Rotating Turbine Engine Work Stands



## Standard Features:

**Models: 08-2021C0000, 08-2220C0000**

- Manual gear driven 360° rotation with safety locks at 3° intervals
- Sturdy welded steel construction
- Towbar stores away for ease of engine maintenance
- Heavy duty 6 in (15 cm) casters with 2 swivel and 2 rigid for easy maneuvering
- Two foot operated floor locks stabilize stand during maintenance operation
- Handy oil recovery pan to avoid damage to hangar floors
- Multiple engine adaptability (engine adaptor kits sold separately)
- Non-slip work/walking surfaces
- Adaptors change in minutes
- Finish: Durable Powder Coat Tronair Blue

## Standard Features:

**Model: 08-2023-0010**

- 45° positioning wheel with ball lock pin secures engine giving 8 angles of maintenance access
- Sturdy welded steel construction
- Easy maneuvering with 2 swivel and 2 rigid heavy duty casters
- Center foot operated grips firmly to stabilize stand during maintenance operation
- Handy oil recovery pan to avoid damage to hanger floors
- Finish: Durable Powder Coat Tronair Blue



08-2021C0000

## Adaptor Kits:

**08-2021C0000**

- **K-1795** - Garrett TFE731-1 to 5
- **K-1796** - Pratt & Whitney JT15D
- **K-2032** - Williams FJ44
- **K-3215** - Garrett TFE731-20 & 40
- **K-3861** - Garrett TFE731-60
- **K-3994** - Pratt & Whitney PW615F-A
- **K-4030** - Williams FJ33
- **K-4071** - Pratt & Whitney PW615F-A Lord Mounting
- **K-4190** - Williams FJ44-4

**08-2220C0000**

- **K-4009** - Williams FJ33
- **K-4131** - Williams FJ44-4

**08-2023-0010**

- **K-2108** - Rolls Royce (Allison) 250-C18, 20, C28, 30
- **K-2110** - Garrett TPE331
- **K-2111** - Lycoming LTS101

# Portable Turbine Engine Change Stand

## Standard Features:

- Heavy duty 8 in (20 cm) casters
- Sturdy welded steel construction
- Floor locks for stability
- Finish: Durable Powder Coat Tronair Blue

## Adaptor Kits:

- **K-2112** - Garrett TFE731-1 to 5
- **K-2113** - General Electric CF700
- **K-2114** - General Electric CJ610
- **K-2115** - Pratt & Whitney PT6A-1 to 3 & 36
- **K-2116** - Pratt & Whitney PT6A-41 to 65 (except A50)
- **K-2117** - Pratt & Whitney JT15D

## Slings: Can become integral part of stand

- **08-0100-4000** - General Electric CF700 & CJ610  
Pratt & Whitney PT6A-1 to 36
- **08-0102-4010** - Garrett TFE731-1 to 5  
Pratt & Whitney PT6A-B36, PTA6A-38 & 41 to 65 (except 50)
- **08-0114-4010** - Pratt & Whitney JT15-D-1B, 4B, 4D, 5, 5D  
(JT15D-5D requires adaptor kit K-2478)

Engine Sling  
(not included,  
see Engine Slings)

Engine Adaptor  
(not included,  
see Adaptor Kits)



08-2001-0000

[www.tronair.com](http://www.tronair.com)

Tronair • Email: [sales@tronair.com](mailto:sales@tronair.com) • Phone: 419-866-6301 or 800-426-6301 • Fax: 419-867-0634

Asia Sales Offices: China - Email: [tronairchina@tronair.com](mailto:tronairchina@tronair.com) • Phone: 86-592-5560735 • Fax: 86-592-5563132

Asia/Australia - Email: [tronairasia@tronair.com](mailto:tronairasia@tronair.com) • Phone: 662 2121463 • Fax: 662 2121332

Europe, Middle East & Africa Sales Office • Email: [saleseurope@tronair.com](mailto:saleseurope@tronair.com) • Phone: 44-0-113-245-3300 • Fax: 44-0-113-322-0436

TR012913