

These test procedures shall be complied to, without exception, annually.

Model Number _____ Serial Number _____

Tested By _____ Date _____

Slings shall undergo periodic load tests at least every year at a specific load test factor of the design rated load. All components shall be tested together as a system, if practical. Slings used infrequently for critical lifts shall be load tested for each critical lift if it has been over a year since the last load test.

SPECIFICATIONS

Rated capacity of Nacelle Mounted Hoist: 1,550 lbs

The hoist should be visually inspected before each use for signs of fatigue. This includes any cracks or irregularities resulting from use.

08-5004-0000, 08-0116-5000, AND 08-0132-0000 NACELLE MOUNTED HOISTS

1. Install hoist into weld/test fixture.
2. Increase cylinder pressures:
Cylinder 1: 190 psig + 10 psig (1,143 lbs)
Cylinder 2: 250 psig + 10 psig (1,526 lbs)
Cylinder 3: 81 psig + 10 psig (573 lbs)
3. Hold fixture load for one (1) minute.
4. Slowly release cylinder pressure.
5. Visually inspect all parts for cracks and/or irregularities resulting from testing.
6. If any irregularities are found, parts are to be discarded or returned to Tronair for evaluation.

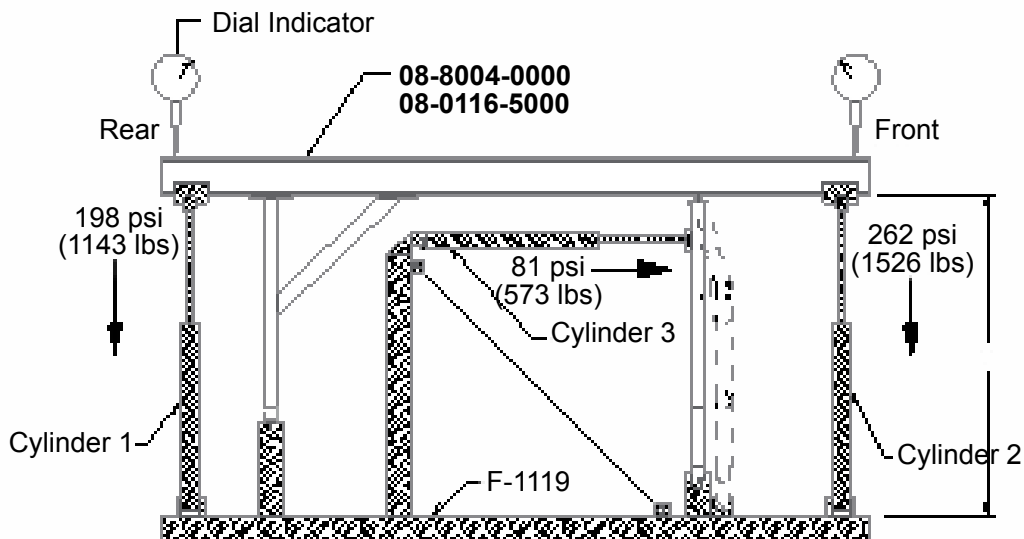

All Three Cylinders Are 3" Ø With 1 1/8" Ø Ram

Z-1470, Z-1469-01 AND Z-1469-02 ENGINE STRAPS

1. Attach each strap separately to a Hydraulic Test Fixture and apply a hydraulic test load of 145 psig + 10 psig (1,530 lbs.) to strap.
2. Hold load for one (1) minute minimum.
3. Release load and visually inspect all parts for cracks and/or irregularities resulting from testing.
4. If any irregularities are found, parts are to be discarded or returned to Tronair for evaluation.

08-0136-0010 AND 08-0137-6000 ENGINE STRAPS

1. Mount sling strap to be tested onto fixture.
2. Position sling blocks as shown.
3. Apply proof load of 2,500 lbs (245 psi) and hold for approximately one minute.
4. Remove sling strap from test fixture and inspect the entire strap for any signs of failure, i.e., broken or cracked welds, elongated holes, or cracks in any other portion of the strap.
5. Any component which does not successfully pass the test is to be discarded or returned to Tronair for evaluation.

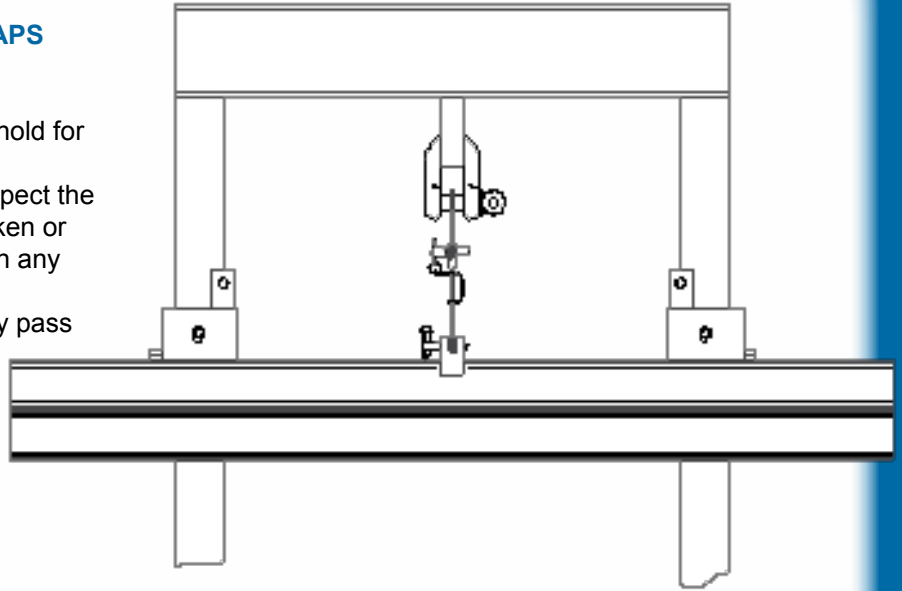

08-0136-0010 NACELLE MOUNTED HOIST

1. Modify trolley assemblies by replacing R-1859-01 with F-1602-B fixture component.
2. Mount nacelle mounted hoist on test stand.
3. Install fixture component into the trolley assemblies.
4. Install hydraulic cylinder and load cell.
5. Pull nacelle mounted hoist to 4,000 lbs and hold load for one (1) minute.
6. Remove hoist from the test fixture and inspect the entire system for any signs of failure.
7. Change trolley pins back to R-1859-01.
8. If any irregularities are found discard or returned to Tronair for evaluation.

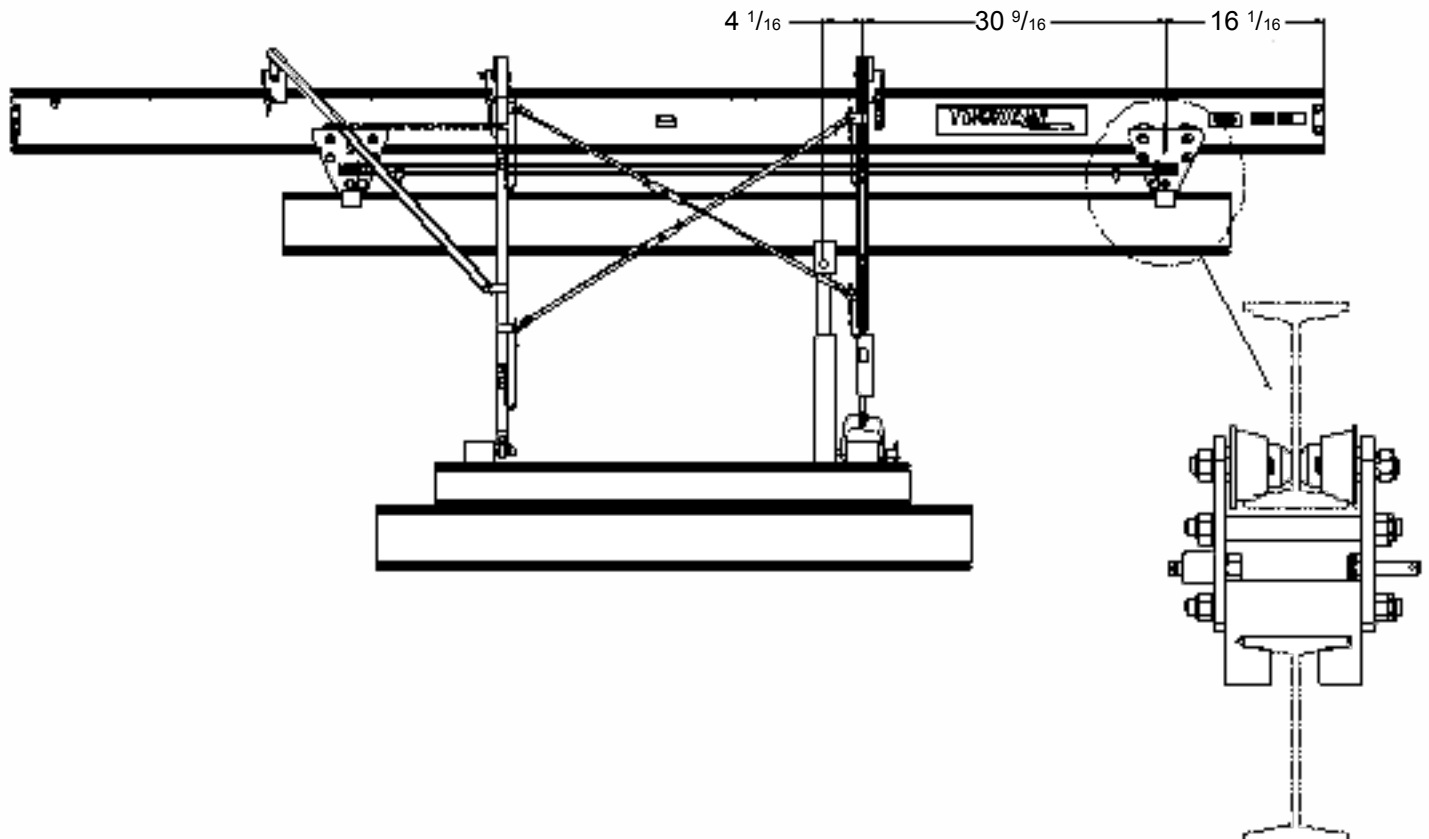

www.tronair.com

Tronair • Email: sales@tronair.com • Phone: 419-866-6301 or 800-426-6301 • Fax: 419-867-0634

Asia Sales Offices: China - Email: tronairchina@tronair.com • Phone: 86-592-5560735 • Fax: 86-592-5563132

Asia/Australia - Email: tronairasia@tronair.com • Phone: 662 2121463 • Fax: 662 2121332

Europe, Middle East & Africa Sales Office • Email: saleseurope@tronair.com • Phone: 44-0-113-245-3300 • Fax: 44-0-113-322-0436

TR062413