

Legend:
 △ Aircraft primary tripod jack location
 □ Aircraft auxiliary tripod jack location
 ○ Aircraft axle jack location

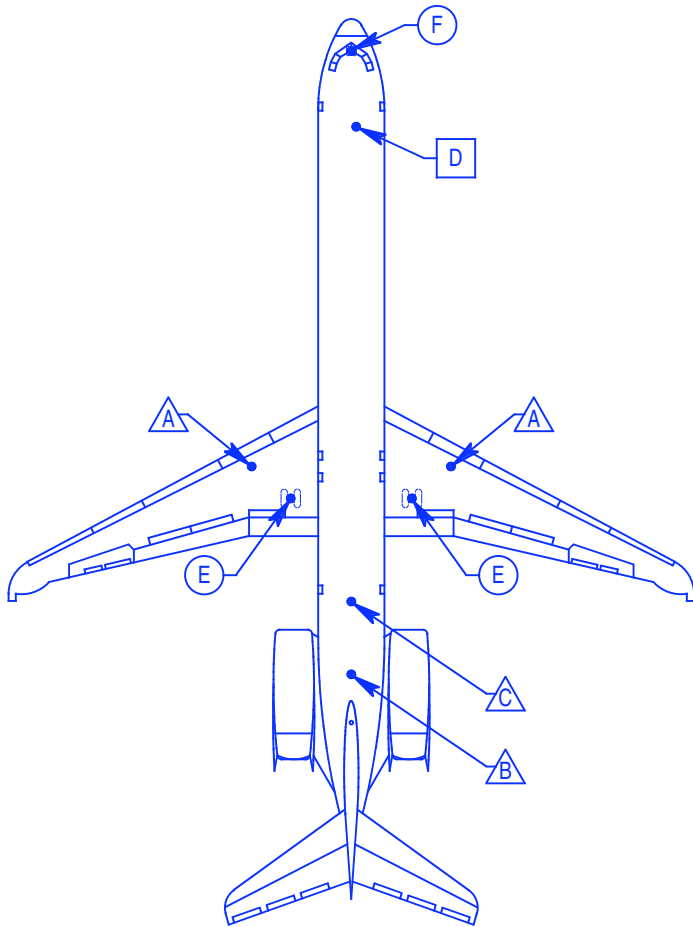

**FOR ALTERNATE JACK SELECTIONS, REFER TO
 "RECOMMENDED MALABAR AIRCRAFT JACK MODELS" CHART**

AIRCRAFT DATA						MALABAR JACK MODELS AND DATA					
REF.	LOCATION & SERVICE	MAX. JACK LOAD	MIN. HT.	MAX. HT.	DISTANCE BETWEEN TIRES	MODEL	CAP.	MIN. HT.	HYD. LIFT	SCR. EXT.	MAX. HT.
A	Main Wing: Gear Swing	22.1 (20.0)	57.00 (1448)	95.00 (2413)		7120A	25 (22.7)	50 (1270)	36 (914)	10 (254)	96 (2438)
	Main Wing: Oleo Removal			97.00 {1} (2464)							
	Aft w/o Stair: Gear Swing			10.7 (9.7)							
B	Aft w/o Stair: Oleo Removal			92.00 {1} (2337)		7120A	25 (22.7)	50 (1270)	36 (914)	10 (254)	96 (2438)
	Aft w/ Stair: Gear Swing	10.7 (9.7)	43.00 (1092)	82.00 (2083)		7212B	12 (10.9)	30 (762)	40 (1016)	8 (203)	78 (1981)
C	Aft w/ Stair: Oleo Removal			84.00 {1} (2134)							
	Forward: Gear Swing	7.0 (6.4)	32.00 (813)	51.00 (1295)		7210B	10 (9.1)	25 (635)	36 (914)	6 (152)	67 (1702)
D	Forward: Oleo Removal			59.00 {1} (1499)							
	MLG: Routine	38.2 (34.7)	13.10 (333)	19.40 (493)	9.50 (241)	50P9AR	50 (45.4)	9.13 (232)	9.75 (248)	4.13 (105)	23 (584)
E	MLG: Flats		8.00 (203)		0						
	NLG: Routine	7.4 (6.7)	8.50 (216)	11.60 (295)	6.00 (152)	642S	10 (9.1)	6 (152)	8.25 (210)	3 (76)	17.25 (438)
F	NLG: Flats		6.60 (168)		0						

Notes:

- **Caution:** Aircraft manufacturer's specifications and instructions must be followed. In the event of contradiction between aircraft manufacturer's specifications and Malabar's, aircraft manufacturer's specifications will prevail.
- Capacities shown in tons and (metric tons). Dimensions shown in inches and (millimeters).
- Tripod jack point heights are based on:
 - Main & nose landing gear strut oleos at normal operating empty weight (OEW).
 - Main gear tires 40 x 14.
 - Nose gear tires 26 x 6.6.
 - All tires at normal inflation pressure.

{1} Dimensions apply without wheels and tires.

**MALABAR INTERNATIONAL, A TRONAIR COMPANY
 SWANTON, OHIO**

**DOUGLAS DC9
 AIRCRAFT / JACK DATA**

REVISED DATE: FEBRUARY 25, 2013